

Engineering Specification

Job Name _____

Contractor _____

Job Location _____

Approval _____

Engineer _____

Contractor's P.O. No. _____

Approval _____

Representative _____

LEAD FREE*

Series 994 Reduced Pressure Zone Assembly

2½" – 10"

Series 994 Reduced Pressure Zone assembly is designed to provide protection of the potable water supply in accordance with national codes. This series can be used where approved by the local authority having jurisdiction on health hazard cross-connections. Series 994 features a short lay length, lightweight stainless steel body, corrosion resistant stainless steel relief valve, and patented torsion spring check valves.

The series includes a flood sensor to detect excessive water discharges from the relief valve. The sensor is installed on the assembly exterior and does not alter assembly functions or certifications. The sensor relays a signal that triggers notification to facility personnel for corrective action, thus limiting flooding and costly damage.

NOTICE

An add-on connection kit is required to activate the flood sensor. Without the connection kit, the flood sensor is a passive component that does not communicate with any other device. (A retrofit sensor connection kit is also available for existing installations. For more information, download RP/IS-994/994RPDA.)

Features

- Stainless steel construction provides long term corrosion resistance and maximum strength
- Stainless steel body is half the weight of competitive designs reducing installation and shipping costs
- Short end-to-end dimensions makes retrofit easy
- Bottom mounted relief valve reduces clearance requirements when installed against an outside wall
- Torsion spring check valves provides maximum flow at low pressure drop
- Thermoplastic and stainless steel check valves for trouble-free operation
- No special tools required for servicing
- Compact construction allows for smaller enclosures
- Stainless steel relief valve features a balanced rolling diaphragm to eliminate sliding seals and lower maintenance costs
- Sensor on relief valve for flood detection
- Flood alert feature activated with add-on sensor connection kit, compatible with BMS and cellular network communication

*The wetted surface of this product contacted by consumable water contains less than one quarter of one percent (0.25%) of lead by weight.



994-0SY with Flood Sensor

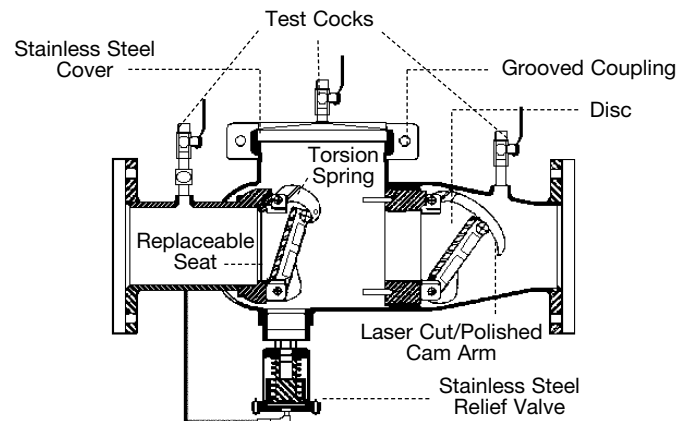

NOTICE

Use of the flood sensor does not replace the need to comply with all required instructions, codes, and regulations related to installation, operation, and maintenance of this product, including the need to provide proper drainage in the event of a discharge.

Watts is not responsible for the failure of alerts due to connectivity issues, power outages, or improper installation.

NOTICE

The information contained herein is not intended to replace the full product installation and safety information available or the experience of a trained product installer. You are required to thoroughly read all installation instructions and product safety information before beginning the installation of this product.

Inquire with governing authorities for local installation requirements.

Specification

A Reduced Pressure Zone Assembly shall be installed at each cross-connection to prevent backsiphonage and backpressure of hazardous materials into the potable water supply. The assembly shall consist of a pressure differential relief valve located in a zone between two positive seating check valves. The main valve body shall be manufactured from 300 Series stainless steel for corrosion resistance. The check valves shall be of thermoplastic construction with stainless steel hinge pins, cam arm, and cam bearing. The check valve shall utilize a single torsion spring design to minimize pressure drop through the assembly. The check valves shall be modular and shall seal to the main valve body by the use of an O-ring. There shall be no brass or bronze parts used within the check assembly or relief valve. The use of seat screws to retain the check valve seat is prohibited. All internal parts shall be accessible through a single cover on the valve assembly securely held in place by a two-bolt grooved coupling. The differential relief valve shall be of stainless steel construction and shall utilize a rolling diaphragm and no sliding seals. The relief valve shall be bottom mounted and supplied with a steel reinforced sensing hose. The assembly shall include two resilient seated shutoff valves and four ball-type test cocks. The assembly shall be a Watts Series 994, and shall include a sensor on the relief valve for flood detection.

Model/Option

FS	Sensor on relief valve for flood detection
NRS	Non-rising stem resilient seated gate valves
OSY	UL Classified and FM Approved outside stem & yoke resilient seated gate valves
OSY FxG**	Flanged inlet gate connection and grooved outlet gate connection
OSY GxF**	Grooved inlet gate connection and flanged outlet gate connection
OSY GxG**	Grooved inlet gate connection and grooved outlet gate connection
LF	Without shutoff valves
S	Cast iron strainer

NOTICE

Watts recommends installing a drain line and the required 994AGK-P air gap for the drain line installation. When installing an air gap, attach the air gap brackets directly onto the flood sensor. For more information, download the ES-AG/EL/TC specification at watts.com.

Materials

All internal metal parts	300 Series stainless steel
Main valve body	300 Series stainless steel
Check assembly	Noryl®

Flange dimension in accordance with AWWA Class D

Pressure – Temperature

Temperature Range	33°F–110°F (0.5°C – 43°C) continuous
Maximum Working Pressure	175 psi (12.1 bar)

Standards

AWWA C511-92, CSA B64.5, UL Classified

Approvals



Approved by the Foundation for Cross Connection Control & Hydraulic Research at the University of Southern California, sizes 2½" to 6"

**Options for the gate valve:

- Consult factory for dimensions.
- Available with grooved NRS gate valves; consult factory.
- Post indicator plate and operating nut available; consult factory.

Noryl® is a registered trademark of SHPP Global Technologies B.V.

Dimensions – Weights

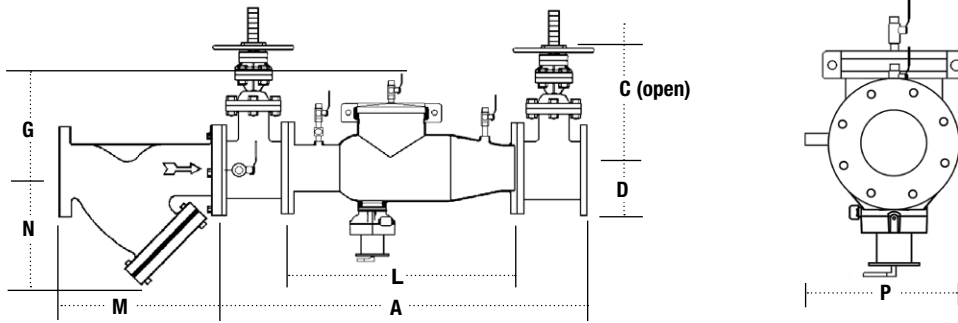

SIZE	DIMENSIONS										WEIGHT											
	A		C (OSY)		C (NRS)		D		G		L		M		N		P		w/Gates		w/o Gates	
in.	in.	mm	in.	mm	in.	mm	in.	mm	in.	mm	in.	mm	in.	mm	in.	mm	in.	mm	lb	kg	lb	kg
2½	37	940	16¾	416	9⅝	238	10½	267	10	254	22	559	10	254	6½	165	7	178	148	67	60	27
3	38	965	18⅞	479	10¼	260	10½	267	10	254	22	559	10⅞	257	7	178	7½	191	226	103	62	28
4	40	1016	22¾	578	12¾	310	10½	267	10	250	22	559	12⅞	308	8¼	210	9	229	235	107	65	30
6	48½	1232	30⅞	765	16	406	11½	292	15	381	27½	699	18½	470	13½	343	11	279	380	172	110	50
8	52½	1334	37¾	959	19⅝	506	12½	318	15	381	29½	749	21⅝	549	15½	394	13½	343	571	259	179	81
10	55¾	1416	45¾	1162	23⅜	605	12½	318	15	381	29½	749	26	660	18½	470	16	406	773	351	189	86

Capacity

Performance as established by Underwriters Laboratories.

*Typical maximum flow rate (7.5 ft/sec)

**UL rated below

